



I – 1. SCOPE

This data describes the standard information (not items guaranteed) expect specifications for the detail design and work. Users shall consider the other information.

I – 2. MASS

The typical mass of the module is 14.0 kg.

I – 3. ELECTRICAL OUTPUT

When the maximum power is 120.0 W, the electrical characteristics of the module under standard test condition are shown in the following table.

Table Electrical characteristics

Characteristics	Symbol	@120.0 W	Unit
Open circuit voltage	Voc	21.3	V
Maximum Power voltage	Vpm	17.1	V
Short circuit current	Isc	7.81	A
Maximum Power Current	Ipm	7.02	A
Maximum Power	Pm	120.0	W

The above electrical characteristics are based on the result of the production line test. These electrical characteristics are different from the

rated electrical characteristics described in the name plate label. There electrical characteristic of the module under not standard test condition is shown in the following

- (1) Fig 1-1: Characteristics regarding Open circuit voltage and short circuit current versus Irradiance
- (2) Fig 1-2: Characteristics regarding Current and Power versus voltage per Irradiance
- (3) Fig 1-3: Normalized Characteristics regarding Open circuit voltage, Short circuit current and Maximum power versus Cell temperature

I – 4. WARNING

Please obey the instructions mentioned below for actual use of this module.

I – 4.1 Uses

- (1) Main applications of the modules as follows.
 - Telemeter System
 - Microwave Repeater Station
 - Other Telecommunication System (Terminal)
 - Village electrification
 - Monument
 - Toy
 - etc.
- (2) Please take proper step in order to maintain reliability and safety, in case this module is used for the users or in area mentioned below which require high reliability.
 - Fallen snow area
 - Extremely cold area
 - Strong wind area
 - Over water
 - Always water area
 - Salt water damage area
 - Small island
 - Desert area
 - Unit concerning control and safety of a vehicle (air plane, train, automobile etc.)
 - Traffic signal
 - Road sign
 - Security System
 - Other safety system

- etc.
- (3) Please don't use for the users mentioned below which require extremely high reliability.
- Space equipment
 - Telecommunication system (relating to any fatal element) etc.
 - Nuclear control system (Trunk)
 - Medical system (relating to any fatal element)
 - etc.
- (4) Please do not connect the modules directly to the leads such as motor since the variation of the output power depending on the solar irradiation causes the damage for the connected the motor.
- 1: In case of brush less motor, the lock function gets active and the hall IC is most likely to be damaged.
 - 2: In case of the motor with brush. The coin is most likely to be damaged.

I – 4.2 Handling

- (1) Never touch the output terminal with bare hands when the module is irradiated. Cover the surface of the module by sufficiently thick cloth or something suitable to prevent incident high, and handle the output terminals with robber-gloved hands not to receive the electric shock.
- (2) Do not drop tools or hard things on the front cover of the module. When broken of the front cover of the module, never use the module.
- (3) Do not scratch the back cover by hard things. Do not wear the metallic jewelry which may become cause of the electric shock during installation.

I – 4.3 Installations

- (1) When mounting the module on structure. Keep the displacement of the forth corner of the module smaller than 2mm for 1000mm of the diagonal of the module after other 3 corners are placed on structure.
- (2) Be careful in handling polarity of insulated output wires.
- (3) Install module and ground frames (support structure) in accordance with applicable law of each country.
- (4) Consult the government office before the installation of the modules in case that the permission of the installation required by law.

- (5) The modules shall be installed and maintained by qualified personnel.
- (6) Follow safety precaution of the battery manufacturer if batteries are used with modules.
- (7) Consult manufacturer for proper installation on special vehicle such as boats and campers.
- (8) Module shall be fastened with 4C-holes with M8-bolts for with standing load 24000Pa.
- (9) Please do not block up D-holes on the establishment.

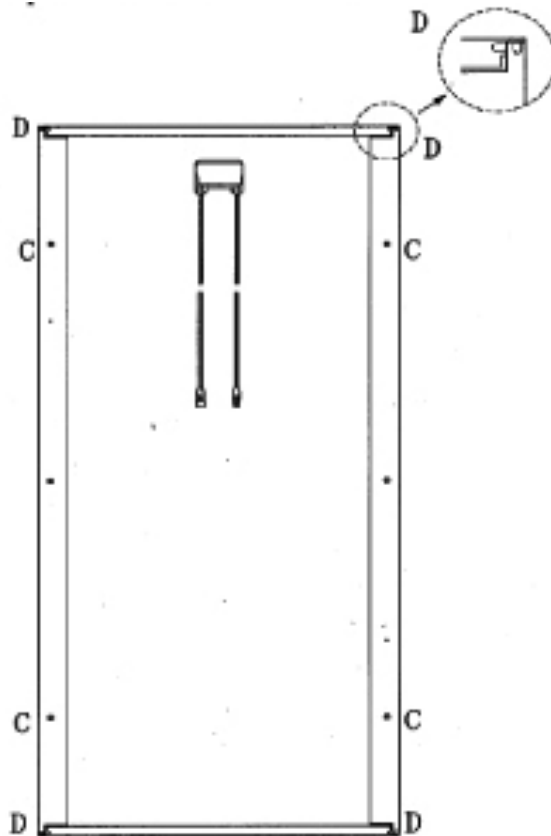

I – 4.4 Operation

- (1) When a part of the modules is shadowed, the hot spot may be caused. Therefore do not shadow cells.
- (2) The module shall be maintained by qualified personnel.
- (3) The electrical characteristics degrade when the front cover of the module becomes dirty.
- (4) Do not pour solvent on the modules when cleaning.
- (5) Do not produce spark near flammable vapors.
- (6) Do not expose the modules to sunlight concentrated with mirrors, lenses or similar means.
- (7) Keep module away from children.

Model: ND-120T1
(Cell Temperature : 25°C)

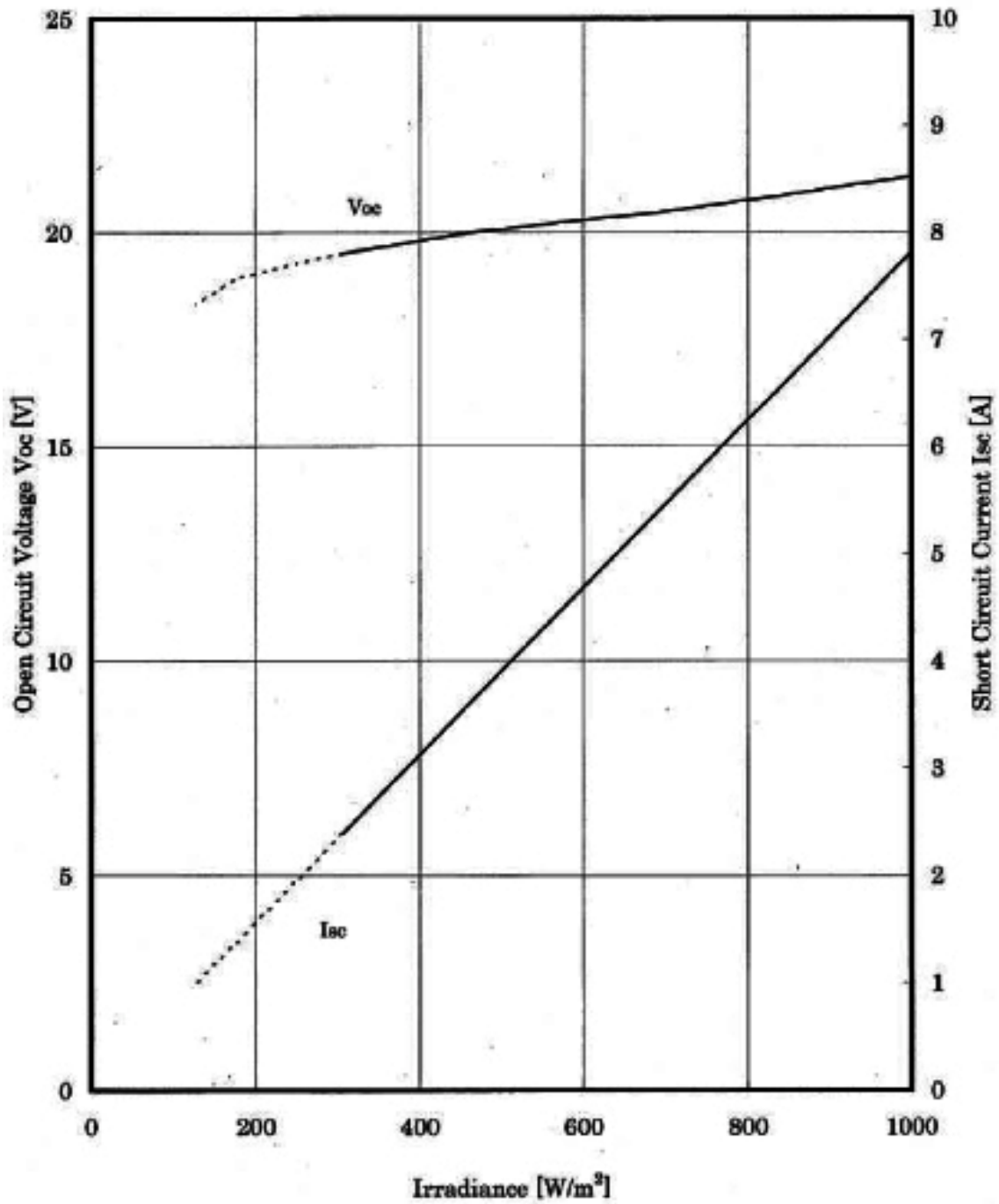

Fig. I -1 Open Circuit Voltage , Short Circuit Current vs. Irradiance Characteristics.

Model : ND-120T1
(Cell Temperature : 25°C)

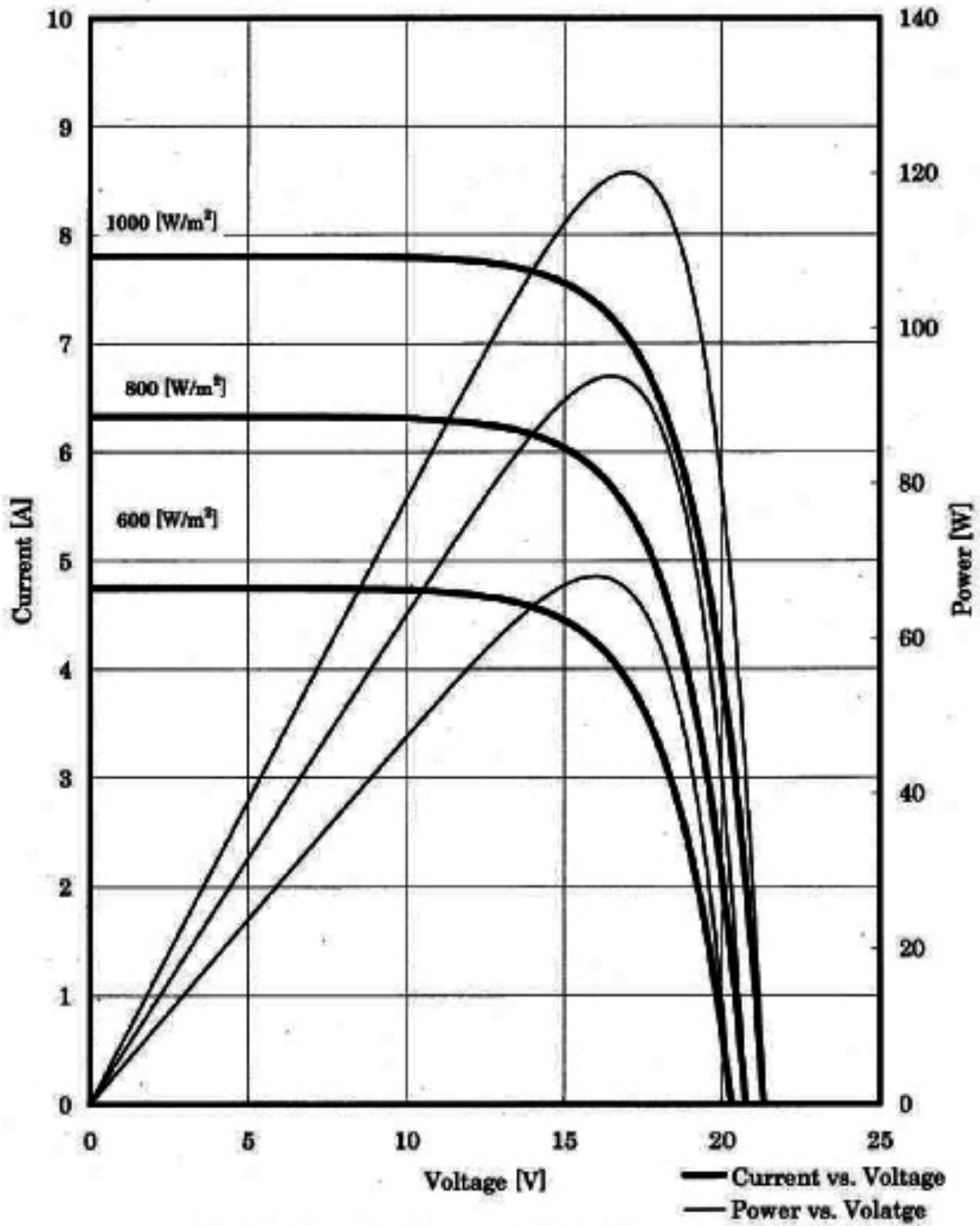
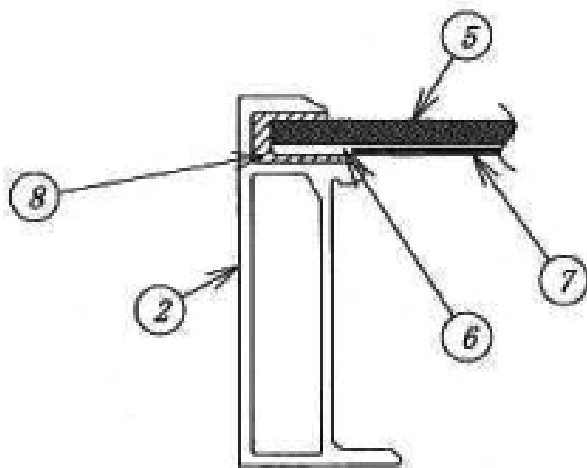
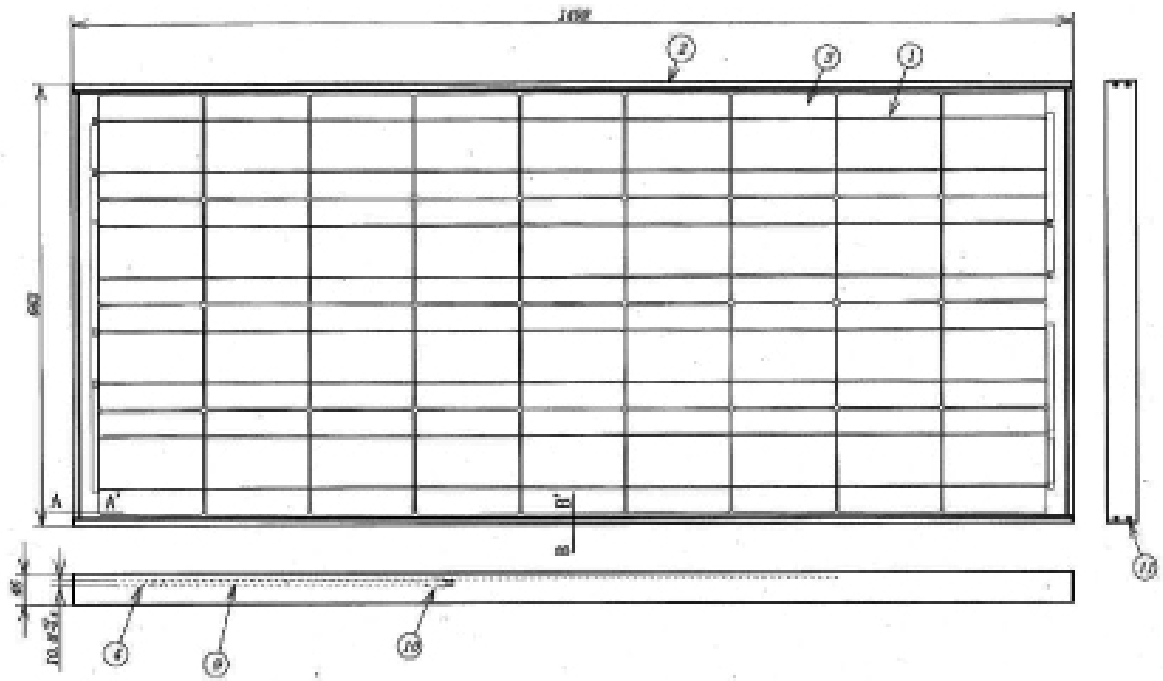
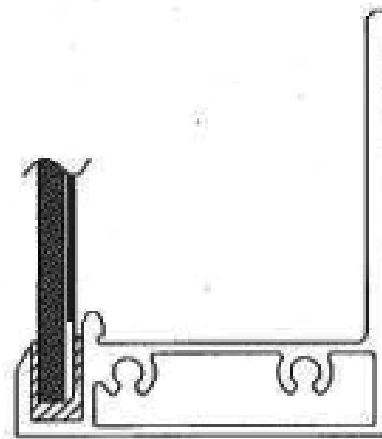

Fig. I -2 Current , Power , vs. Voltage Characteristics



A - A' Cross Section



B - B' Cross Section

Fig. 1